

Advantages of Disposable Flow Transducers

Advantage #1: Our innovative design prevents cross-contamination.

The air inside the flow transducer's measurement pipe works as a buffer, preventing the expired air from entering the pressure tubing even during high flow rates (15 l/s) and repeated spirometry efforts.

The maximal differential pressure signal of the flow transducer is ± 77 mm H₂O, corresponding to a flow of ± 15 l/s. Average atmospheric pressure is 10 000 mm H₂O. The air is therefore compressed in the pressure tubing up to

$$77 / 10\,000 \text{ parts} = 0.77 \%$$

In 2-meter long pressure tubing, this amounts to

$$0.77 \% \times 2000 \text{ mm} = 15.4 \text{ mm}$$

Since the internal diameter of the pressure tubing is 1.5 mm, the cross-sectional area is 1.77 mm². The amount of air entering the flow transducer's measurement pipe during the expiration amounts to

$$15.4 \text{ mm} \times 1.77 \text{ mm}^2 = 27.2 \text{ mm}^3$$

This is the maximal volume of expired air entering the measurement pipe of the flow transducer via the pressure-sampling hole at the top of the measurement pipe. In the measurement pipe, the "contaminated" air will start moving toward the pressure tubing adapter. The air entering the measurement pipe through the hole at the top of the measurement pipe will potentially reach the pressure tubing first.

Because the maximal volume of expired air entering the measurement pipe of the flow transducer is 27.2 mm³, and the air volume in the measurement pipe between the adapter and pressure-sampling hole is 136.3 mm³, the air buffer between the contaminated air and the pressure tubing adapter is

$$136.3 \text{ mm}^3 - 27.2 \text{ mm}^3 = 109.1 \text{ mm}^3$$

This air buffer prevents the aerosols of the contaminated air from entering the pressure tubing even during repeated forced expiratory efforts. In slow efforts, the air entering the measurement pipe is even smaller.

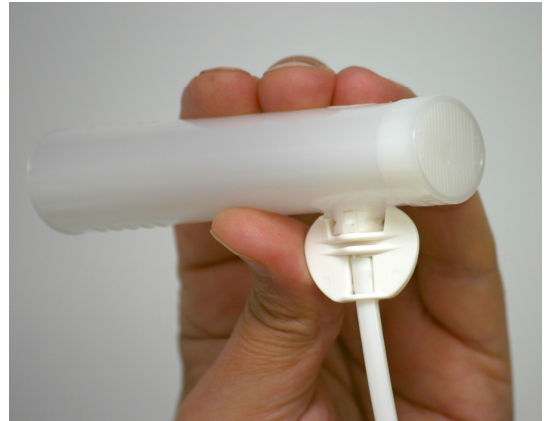

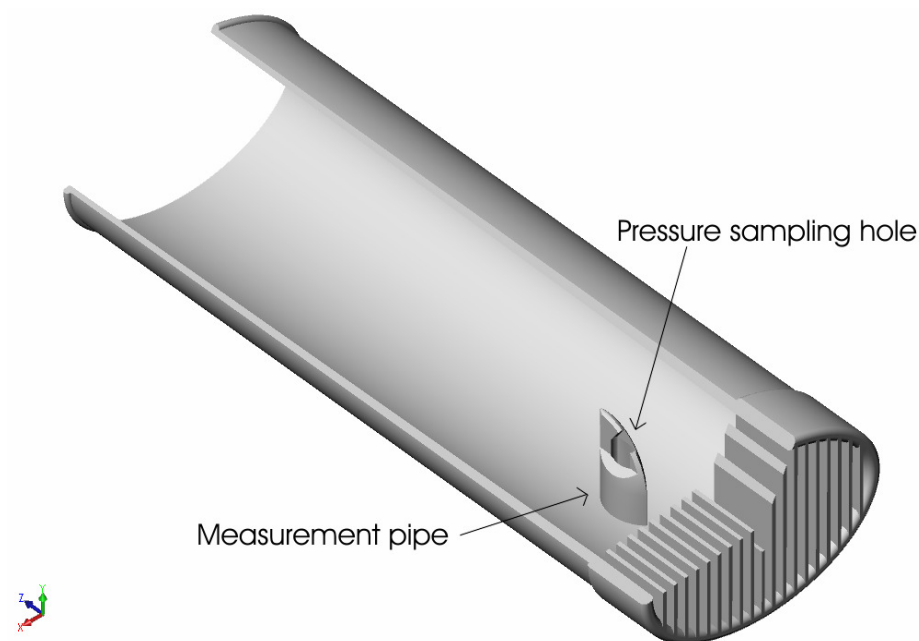

Advantage #2: Bacteria filters are unnecessary.

Because no contaminated air enters the pressure tubing, and because the flow transducers are discarded after each patient use, no bacteria filters are needed. In fact, because Welch Allyn spirometers use a measuring principle based on pressure (pneumotachometer), filters would interfere with accuracy by adding resistance.

Advantage #3: Disposable flow transducers are more cost-effective, accurate, and convenient.

When procedural costs are taken into account, disposable flow transducers cost less than flow transducers that require disinfecting.

A disinfected flow transducer may retain solid particles on the screen or liquids in the duct, compromising accuracy.

Recalibration is required before reusing a disinfected flow transducer, whereas new flow transducers from the same manufacturing lot do not require a separate calibration.